

# Hybrid Inverter

## Three Phase Hybrid Inverter

# User Manual

---

WH-THA 502/602/802/103/123/133



# CONTENTS

<b>1</b>	<b>GENERAL INTRODUCTION.....</b>	<b>1</b>
1.1	System Introduction.....	1
1.2	Safety Introduction.....	1
1.2.1	Warning and Safety Symbols.....	1
1.3	Packing List.....	3
1.4	System Overview.....	4
1.5	Limitation of Liability.....	5
<b>2</b>	<b>INSTALLATION.....</b>	<b>7</b>
2.1	Installation Location and Environment.....	7
2.1.1	General.....	7
2.1.2	Location Restrictions.....	8
2.1.3	Barriers to Habitable Rooms.....	8
2.1.4	Choosing an Installation Location.....	10
2.2	Hybrid Inverter Installation Steps.....	11
2.3	Cable Connections.....	13
2.3.1	PV Connections.....	13
2.3.2	Battery Connections.....	14
2.3.3	EPS Connections.....	15
2.3.4	Grid Connections.....	16
2.3.5	PE Connections.....	17
2.3.6	Inverter Box and Battery Box Connections.....	18
2.3.7	Communication Connections.....	19
2.3.7.1	BMS Connections.....	19
2.3.8	Wi-Fi Dongle Connection.....	22
2.3.9	System Wiring Diagram.....	23
<b>3</b>	<b>EMERGENCIES.....</b>	<b>26</b>
3.1	Emergency Procedures.....	26
3.2	First Aid Procedures.....	26
3.3	Firefighting Measures.....	27
<b>4</b>	<b>CONFIGURATION &amp; WI-FI RELOAD.....</b>	<b>28</b>
4.1	Preparations.....	28
4.2	Wi-Fi Reset & Restore.....	29
4.3	Change Password & Delete Account.....	30
<b>5</b>	<b>EMS CONFIGURATIONS.....</b>	<b>33</b>
<b>6</b>	<b>TROUBLESHOOTING.....</b>	<b>34</b>
<b>7</b>	<b>CLEANING AND MAINTENANCE.....</b>	<b>38</b>
7.1	Cleaning.....	38
7.2	Maintenance.....	38
<b>8</b>	<b>ANNEX.....</b>	<b>39</b>

8.1 Datasheet.....39

**9 LABELS.....42**

## Copyright Statement

JIANGSU WEIHENG INTELLIGENT TECHNOLOGY CO., LTD. (hereinafter referred to as WHES) owns the copyright to this manual. All rights reserved. Please properly store the manual and strictly follow all safety and operating instructions provided. Please do not operate the system before reading through this manual.

## Version Information

Version	Date	Content
V1.0	2023-07-18	
V1.1	2023-12-6	Added the expression for installation clearance
V1.2	2025-04-25	Company brand information change
V1.3	2025-07-01	Added description about installation location near the sea in Section 2.1.4.

# 1 GENERAL INTRODUCTION

## 1.1 System Introduction

WH-THA Series is a high-quality hybrid inverter which can convert solar energy to AC energy and store energy into battery. The hybrid inverter can be used to optimize self-consumption, store in the battery for future use or feed-in to public grid. Work mode depends on PV energy and user's preference. It can provide power for emergency use during the grid lost by using the energy from battery and hybrid inverter (generated from PV). This user manual applies to the following products:

WH-THA502, WH-THA602, WH-THA802, WH-THA103, WH-THA123, WH-THA133.

## 1.2 Safety Introduction

### 1.2.1 Warning and Safety Symbols

#### ● SYMBOLS EXPLANATION



Caution!

Failing to observe warnings indicated in this manual may result in injury.



High voltage and electric shock hazard.



Hot surface.



Recyclable product components.



This side up. The package must always be transported, handled, and stored upright, with the arrows pointing upwards.



Do not stack more than five (5) identical packages on top of each other.



Do not dispose of the product as household waste.



Handle the package/product with care, and do not tip it over or throw it.



Refer to the operating instructions.



Keep dry! The package/product must be protected from excessive humidity and stored covered.



Wait at least 5 minutes after turning off the inverter before touching or using it to prevent electrical shocks or injuries.



## ● SAFETY WARNING

The hybrid inverter must only be installed or operated by qualified electricians in compliance with local grid or power company standards, wiring rules, and requirements.

Disconnect all batteries and AC power sources from the hybrid inverter for at least 5 minutes before connecting any wires or conducting any electrical work to ensure the inverter is totally isolated and to avoid electric shocks.

The surface of the hybrid inverter may exceed temperatures of 60°C during operation. Please make sure the inverter has cooled down before touching it, and make sure that the hybrid inverter is out of the reach of children.

The hybrid inverter must be used and operated as described in this user manual, or safety features may not work as intended, and the warranty for the hybrid inverter will be voided.

Your hybrid inverter warranty will be voided if you open the hybrid inverter cover or change any component without WHES's authorization.

Care must be taken to protect the inverter from static damage. The WEIHENG Limited Warranty does not cover any damage caused by static.

This hybrid inverter features a built-in residual current device (RCMU).





Only use type B external residual current devices (RCD) rated for a tripping current of 30 mA or higher.

This hybrid inverter features active anti-islanding protection, and inverter frequency is shifted away from nominal conditions in the absence of a reference frequency (frequency shift).

This hybrid inverter is a multimode inverter designed to be used in unconditioned outdoor shaded environments. The maximum operating ambient temperature is 60°C.

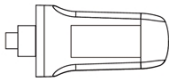
An error message will be sent to the ECOS app in the event of a ground fault, and the status indicator on the product will turn red.

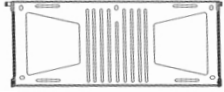
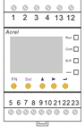

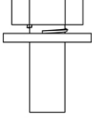
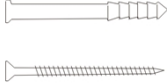



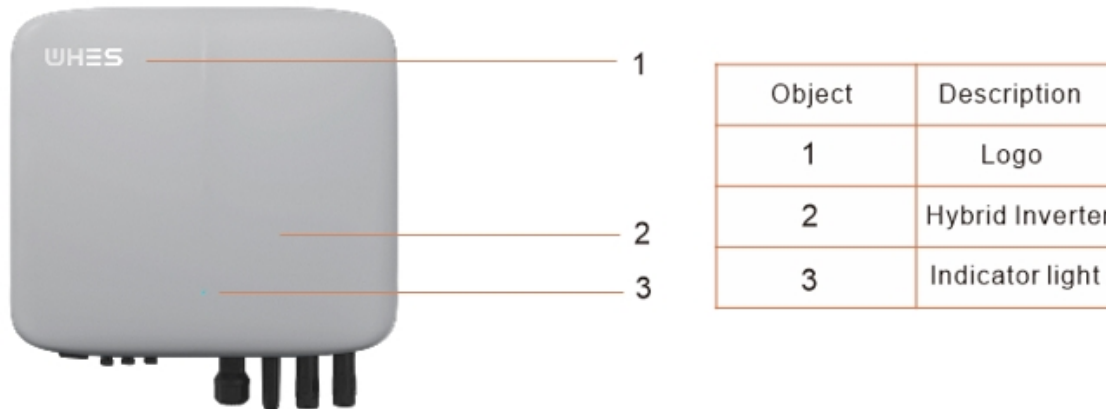

### 1.3 Packing List

WH-THA502/602/802/103/123/133				
				
1 × Wi-Fi Module	Terminal Accessories	Document Accessories	1 × Backplane	
				
1 × Meter (Three Phase Meter)	1 × Quick Installation Guide	2 × M4*14	5 × φ10*60	

## 1.4 System Overview



### LED INDICATOR

STATUS	LED INDICATOR	
Standby		Flashing blue LED, 2-second intervals
Checking		Flashing blue LED, 0.5-second intervals
Normal		Solid blue LED
DSP fault		Solid red LED
Battery com. fault		Flashing red LED, 2-second intervals
Meter com. fault		Flashing red LED, 0.5-second intervals
Copying files		Flashing magenta LED, 0.5-second intervals
Program update		Flashing red and blue (alternating) LED, 1-second intervals

**Hybrid inverter connections:**

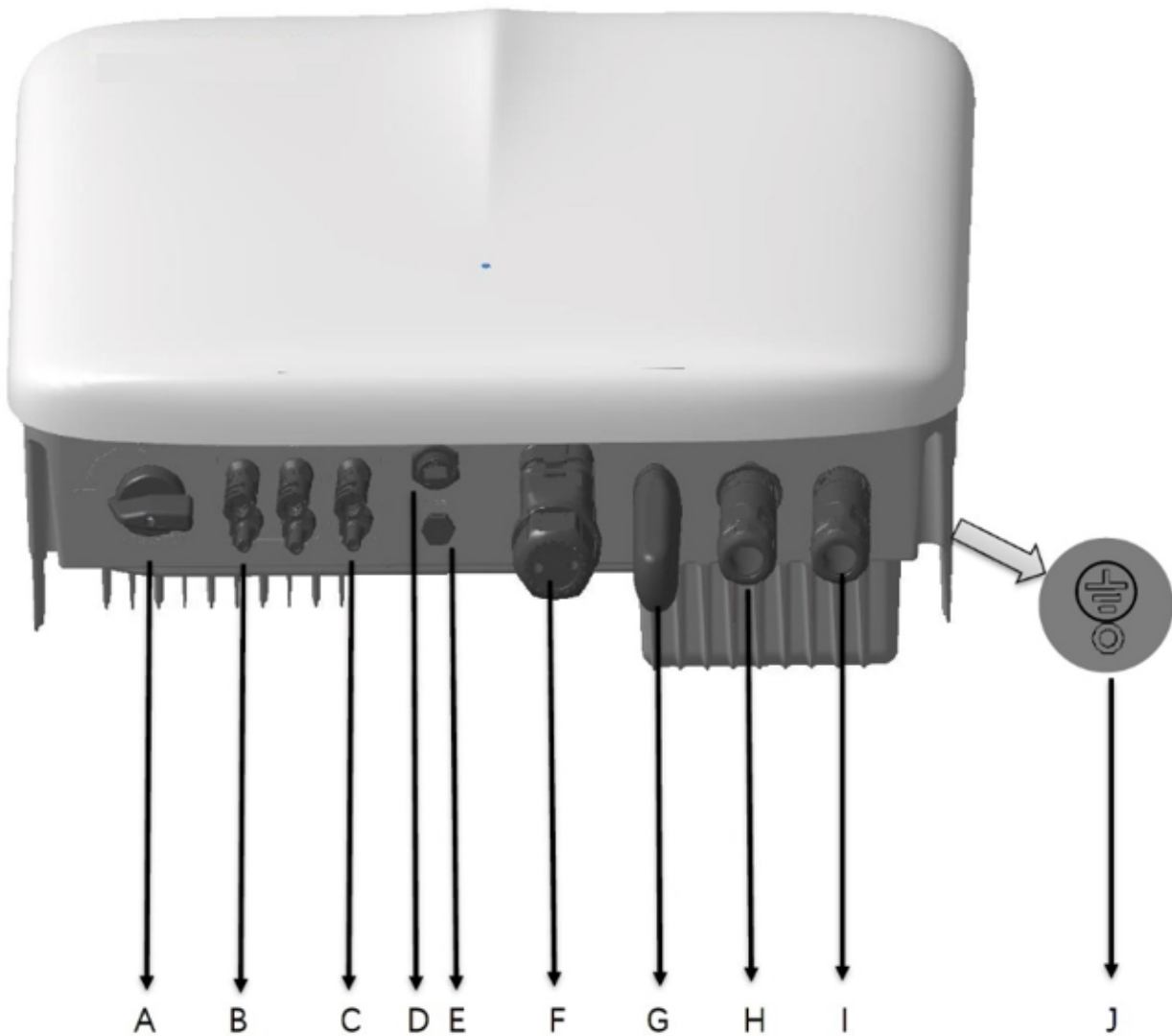

Item	Description	Tool requirements and torque values
A	PV switch	---
B	PV connectors	Torque 2.0 N·m
C	Battery connectors	Torque 2.0 N·m
D	USB	Plug and play connection, no tools required
E	Vent valve	---
F	VPP & BMS & METER & DRM communication port	Torque 2.5 N·m
G	Wi-Fi dongle	Torque 2.5 N·m
H	EPS connectors	Torque 2.5 N·m
I	Grid connectors	Torque 2.5 N·m
J	Ground screw	Torque 2.5 N·m

**1.5 Limitation of Liability**

WHES assumes no direct or indirect liability for any product damage or property

losses caused by the following.

- ◆ Product modifications, design changes, or parts replaced without WHES's authorization;
- ◆ Modifications or attempted repairs or removal of serial numbers or seals by non-WHES technicians;
- ◆ System designs and installations not in compliance with standards or regulations;
- ◆ Failure to comply with the local safety regulations (VDE in DE, SAA in AU, MEA and PEA in Thailand);
- ◆ Damage caused during transportation (including scratched paint caused by the product rubbing against the packaging during shipping). Any claims for damage during shipping should be made directly with the shipping or insurance company as the container/packaging is unloaded and damage is identified;
- ◆ Failure to follow any/all of the user manual, installation guide, or maintenance guidelines;
- ◆ Improper use or misuse of the device;
- ◆ Insufficient ventilation around the device;
- ◆ Product maintenance not done to acceptable standards;
- ◆ Force majeure (including severe or stormy weather, lightning, and fires).

## 2 INSTALLATION

The product must be installed on a flat surface or platform with a load-bearing capacity of at least 120 kg. The installation location should be well-ventilated and away from flammable or explosive materials.

### 2.1 Installation Location and Environment

#### 2.1.1 General

This hybrid inverter is rated for outdoor installation and can be installed both indoors and outdoors. The hybrid inverter is naturally ventilated. The installation location must be clean, dry, and adequately ventilated. Enough space should be left for unrestricted access to the unit for installation and maintenance purposes, and the system panels should not be obstructed.

The hybrid inverter should not be installed in the following locations:

- ◆ Habitable rooms;
- ◆ Ceiling or wall cavities;
- ◆ On roofs not suited for the purpose;
- ◆ Access/exit areas or under stairs/access passages;
- ◆ Places where freezing temperatures can occur, such as garages, carports, or other places such as wet rooms;
- ◆ Humid or salty environments;
- ◆ Seismic-prone areas—additional safety measures are needed;
- ◆ Sites higher than 3000 meters above sea level;
- ◆ Explosive atmospheres;
- ◆ In direct sunlight or places susceptible to significant changes in ambient temperature.

## 2.1.2 Location Restrictions

The hybrid inverter should not be installed:

- (1) Within 600 mm of any heat source, such as hot water units, gas heaters, air conditioning units, or any other similar appliances;
- (2) Within 600 mm of any exit;
- (3) Within 600 mm of any window or ventilation opening;
- (4) Within 900 mm of access to 220/230/240 VAC connections;
- (5) Within 600 mm of the side of any other device.

Leave at least 1 meter of clearance between the hybrid inverter and any emergency exits when installing the device in corridors, lobbies, or hallways to ensure a safe exit.

## 2.1.3 Barriers to Habitable Rooms

Ensure a suitable non-combustible barrier is set up between the hybrid inverter and any installation walls or structures when installing the hybrid inverter on a wall or structure connected to a living space to protect against the spread of fire to living spaces. A non-combustible barrier should be installed between the hybrid inverter and the surface of the wall or structure it is being mounted to if the surface itself is not made out of a suitable non-combustible material. Increase the distance between the hybrid inverter and any other nearby structures or objects if there is less than 30 mm between the hybrid inverter and the wall or structure separating it from living spaces.

The following spaces around the hybrid inverter must remain empty:

Top	-----	300 mm
Bottom	-----	500 mm
Front	-----	300 mm
Left and right sides	-----	200 mm

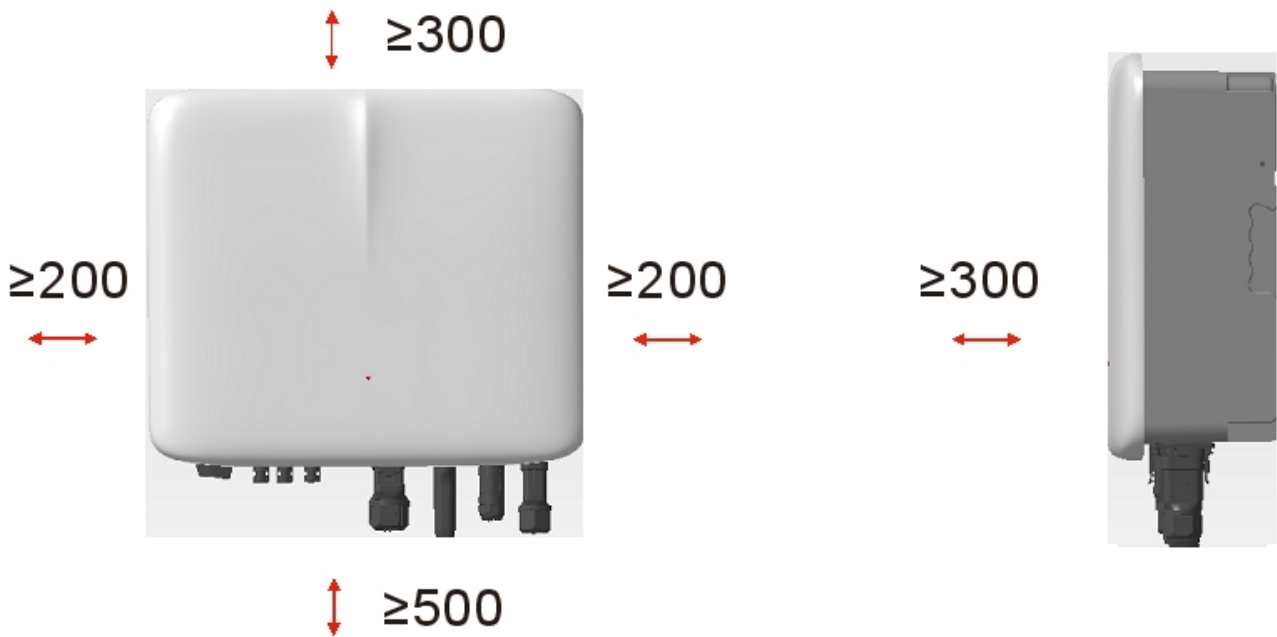

The clearance is a recommendation. Reserve sufficient clearance around the product to ensure sufficient space for installation, maintenance and heat dissipation. If there is a local standard for the installation of energy storage systems, please define the clearance refer to the standard.

### 2.1.4 Choosing an Installation Location



Carefully select an appropriate installation location based on the following rules to protect the hybrid inverter and facilitate maintenance.

**Rule 1.** The hybrid inverter should be installed on a solid surface capable of supporting its size and weight.

**Rule 2.** The hybrid inverter should be installed vertically or at a maximum 15° angle.

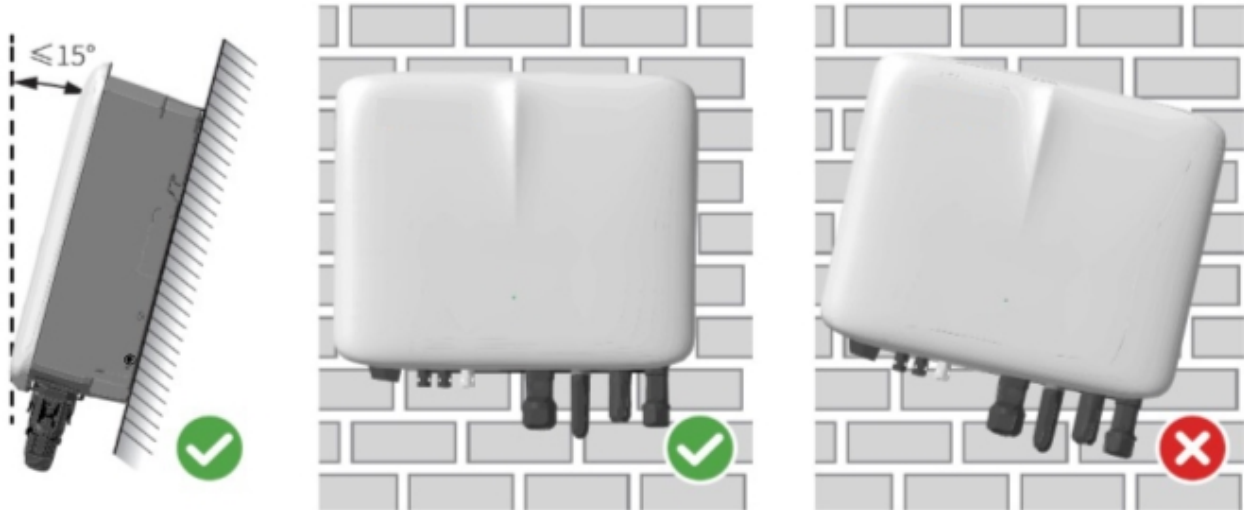

**Rule 3.** The temperature and humidity at the installation site should be within the appropriate range.

**Rule 4.** The inverter installation location should be protected from direct sunlight or bad weather like snow, rain, or lightning.

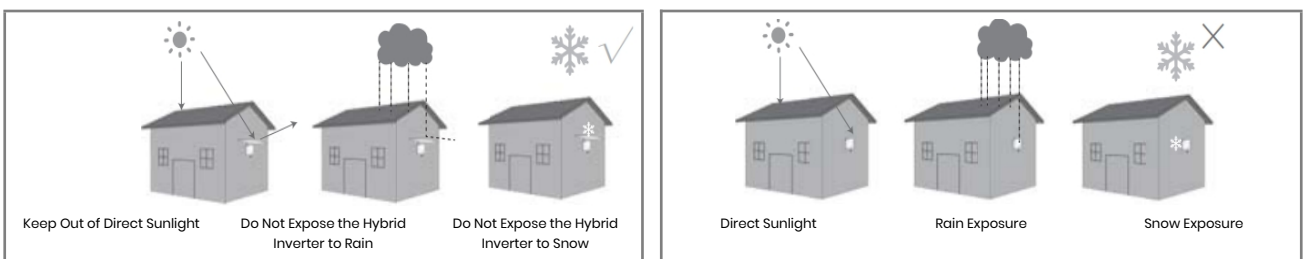

**Rule 5.** Install the system at least 500 meters away from the coast and avoid sea breeze directly hit.

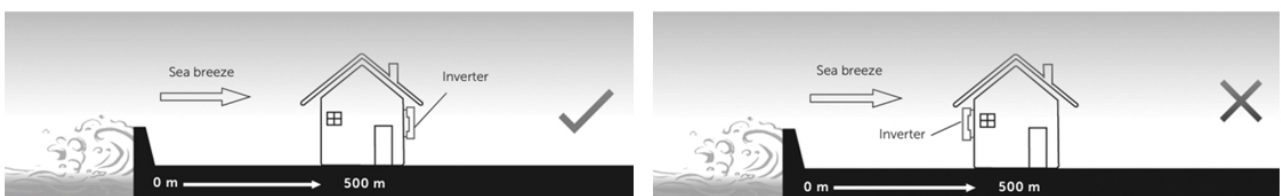

**Rule 6.** Installing the hybrid inverter at eye level will make maintenance more

convenient.

**Rule 7.** The hybrid inverter's product label should be clearly visible after installation.

**Rule 8.** Do not install the inverter in the snow or rain. If installation in the snow or rain is unavoidable, ensure the inverter and distribution box are protected and kept dry.

Install the hybrid inverter away from strong magnetic fields to avoid electromagnetic interference. When installing the hybrid inverter next to radio or wireless communication equipment operating below 30 MHz: 1. Install the inverter at least 30 m away from the wireless equipment. 2. Attach a low-pass EMI filter or a multi-winding ferrite core to the hybrid inverter DC input cable or AC output cable.

## 2.2 Hybrid Inverter Installation Steps



The hybrid inverter must not be installed near flammable or explosive materials or near equipment with strong electromagnetic fields.

The hybrid inverter should only be installed on concrete or other non-combustible surfaces.

Installation Tools:

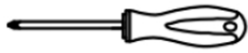

Screwdriver

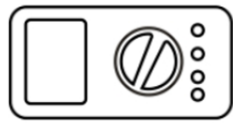

Multimeter



Wire stripper

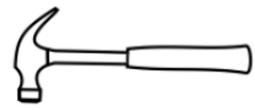

Claw hammer

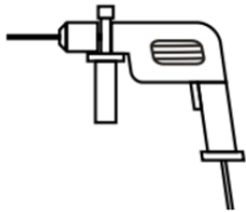

Hammer drill



Diagonal pliers

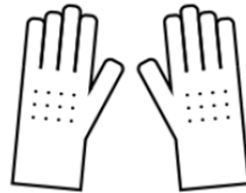

Insulating gloves

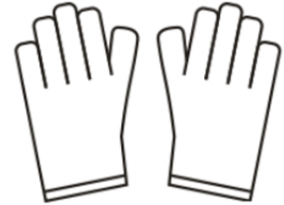

Protective gloves



Crimping pliers

**STEP 1**

Please use the mounting bracket as a template and drill 5 holes in the right positions.

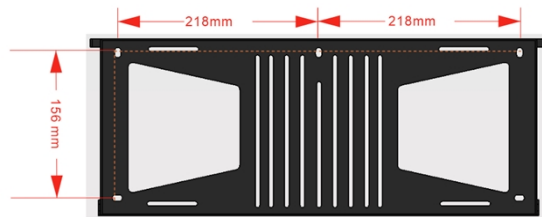

**STEP 2**

Use the included wall anchors in the accessory box to secure the mounting bracket onto the wall.

NOTE: The wall must have a load-bearing capacity of more than 120 kg to ensure it can support the inverter.

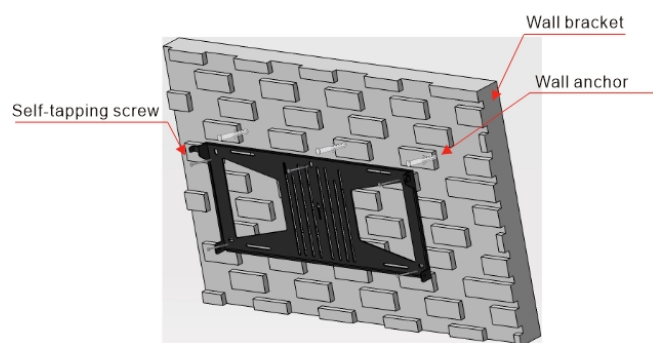

**STEP 3**

Hold the inverter from both sides of the heatsink and attach it to the mounting bracket.

NOTE: Make sure the inverter heat sink is properly aligned with the mounting bracket joint.

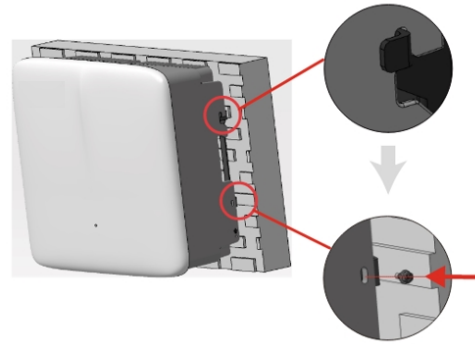

**2.3 Cable Connections**

**2.3.1 PV Connections**

Please make sure you fulfill all the requirements below before connecting PV panels/strings to the inverter:

- The total short-circuit current of a single PV string must not exceed the inverter's max DC current rating.
- Do not connect PV strings to earth/ground conductors.
- Use the appropriate PV connectors in the included accessory box. (BAT connectors look similar to PV connectors. Please double-check before using them.)

Follow the below PV cable requirements.

Legend	Description	Value
A	Outside Diameter	5.5–8.0 mm
B	Insulated Cable Length	7 mm
C	Conductor Core	10 AWG

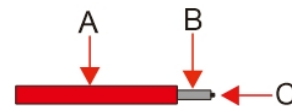

## 1. Crimp the terminal;

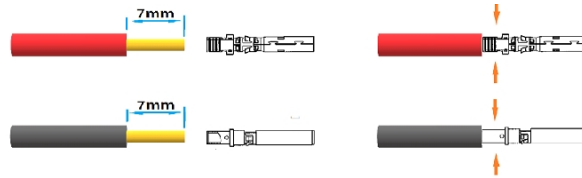

## 2. Insert the terminal into the connector and lock the nut;

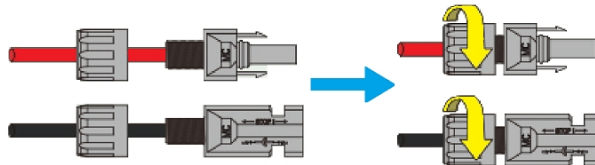

Torque 2.0 N·m

Note: The connectors will make a clicking sound when inserted correctly into the PV plugs.

### 2.3.2 Battery Connections

- Please be mindful of any electric shock or chemical hazards. Always connect an external DC breaker (40 A, 500 V) when working with batteries without built-in DC breakers.
- Do not use lead-acid batteries with the inverters without the necessary permissions.
- Use the appropriate BAT connectors in the included accessory box. (PV connectors look similar to BAT connectors. Please double-check before using them.)

Follow the below battery cable requirements.

Legend	Description	Value
A	Outside Diameter	5.5–8.0 mm
B	Insulated Cable Length	7 mm
C	Conductor Core	8 AWG

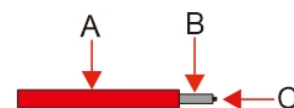

#### Battery wiring connection steps:

## 1. Crimp the terminal;

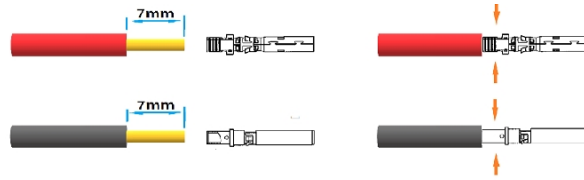

2. Insert the terminal into the connector and lock the nut;

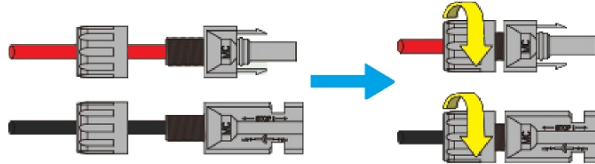

Torque 2.0 N·m

Note: The connectors will make a clicking sound when inserted correctly into the BAT plugs.

### 2.3.3 EPS Connections

#### NOTE

1. Some external factors may cause the backup switching time to exceed 10 ms, and loads reliant on a constant stable energy supply should not be connected.
2. Very high inrush current surges from loads such as fixed-frequency air conditioners and high-power pumps may cause the inverter to switch to the overload protection state.
3. Ensure the EPS load power rating is within the EPS output rating, or the inverter may shut down and give an “overload” warning.
4. Adjust the load power when facing an “overload” warning to one within the EPS output power range, then turn the inverter back on.
5. Make sure the input surge current for any nonlinear loads is within the EPS output power range.

Follow the below EPS cable requirements.

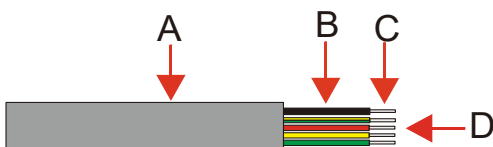

Legend	Description	Value
A	Outside Diameter	8–11 mm
B	Individual Cable Length	25–30 mm
C	Insulated Cable Length	10 mm
D	Conductor Core	10 AWG

**EPS** connection process is as below:

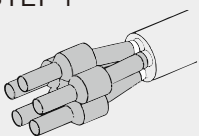
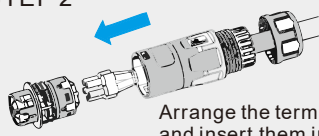
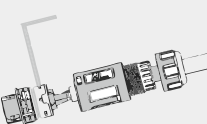
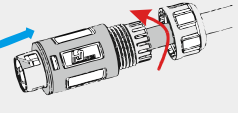
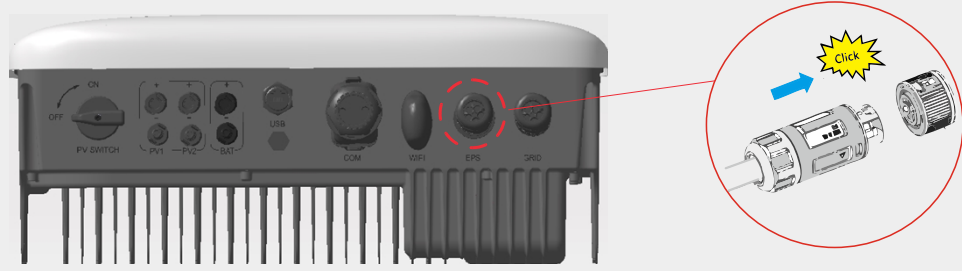
<p><b>STEP 1</b></p>  <p>Use crimping pliers to crimp the terminals</p>	<p><b>STEP 2</b></p>  <p>Arrange the terminals on the cable and insert them in order</p>
<p><b>STEP 3</b></p>  <p>Use a hex key to crimp the inner wires and torque them to <math>1.2 \pm 0.1</math> N·m</p>	<p><b>STEP 4</b></p>  <p>Insert the main cable body into the rubber insulator and use an open-ended wrench to torque the nut to <math>2.5 \pm 0.5</math> N·m</p>
	

### 2.3.4 Grid Connections

An external AC breaker is needed for On-Grid connection to isolate the hybrid inverter from the utility grid when necessary.

## NOTE

Electrical short-circuits on the Back-Up side may damage the inverter if an AC breaker is not installed on the Back-Up side.

- Follow the below GRID cable requirements.

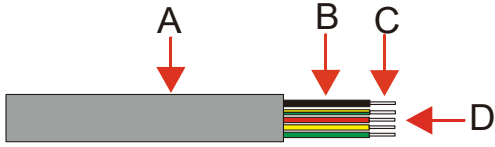

Legend	Description	Value
A	Outside Diameter	15–20 mm
B	Individual Cable Length	25–30 mm
C	Insulated Cable Length	15–17 mm
D	Conductor Core	10 AWG

## NOTE

Use a black wire to indicate the neutral conductor, a red wire (preferred) or a brown wire for the line conductor, and a yellow-green wire for the protective earth bonding line.

- Grid** connection process is as below:

<p><b>STEP 1</b></p> <p>Use crimping pliers to crimp the terminals</p>	<p><b>STEP 2</b></p> <p>Arrange the terminals on the cable and insert them in order</p>
<p><b>STEP 3</b></p> <p>Use a hex key to crimp the inner wires and torque them to <math>2.0 \pm 0.1 \text{ N}\cdot\text{m}</math></p>	<p><b>STEP 4</b></p> <p>Insert the main cable body into the rubber insulator and use an open-ended wrench to torque the nut to <math>2.5 \pm 0.5 \text{ N}\cdot\text{m}</math></p>

### 2.3.5 PE Connections

## NOTE

The PE screw has been pre-installed on the hybrid inverter in advance.

- PE cable** connection process is as below:

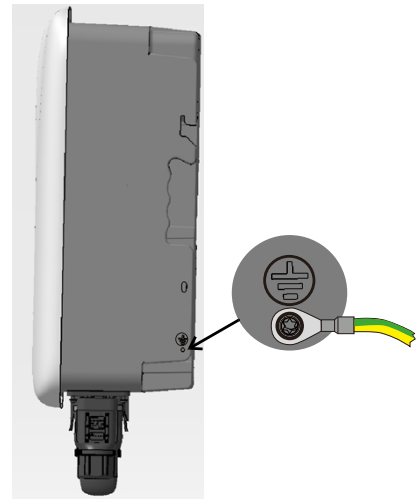
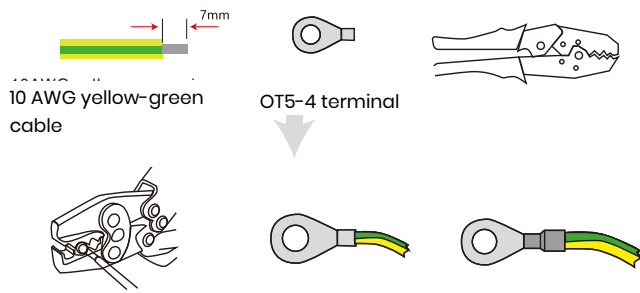

### 2.3.6 Inverter Box and Battery Box Connections

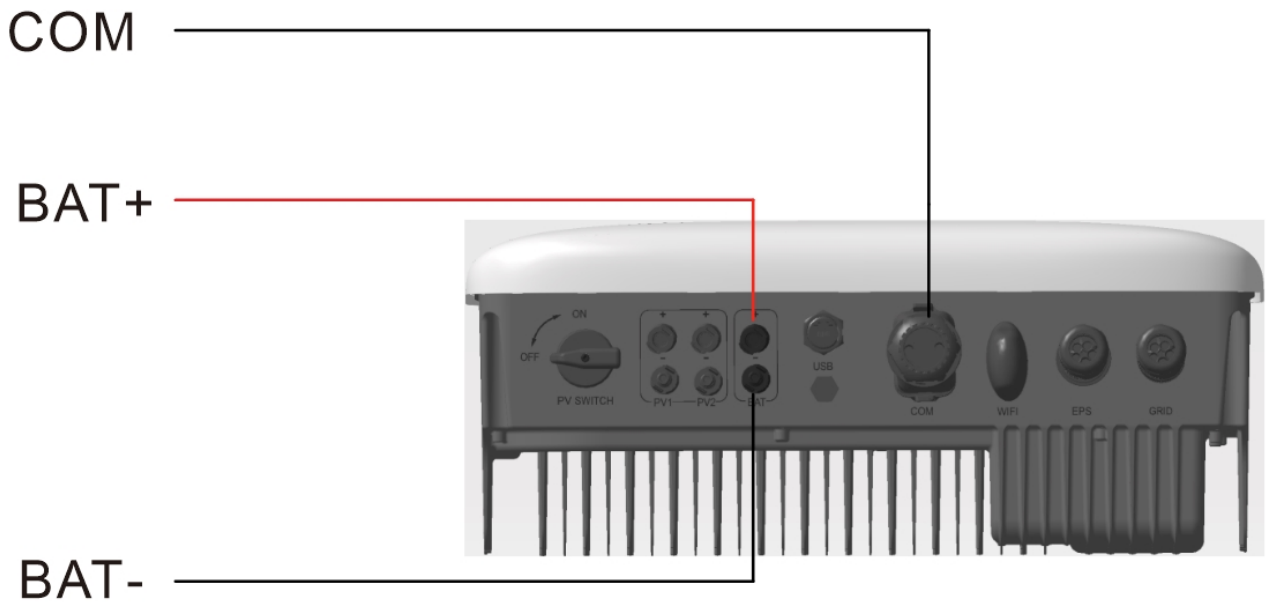

## NOTE

1. Make sure that any batteries selected are included on the WH-THA list of approved batteries before purchase, or the system may not work as intended. Please contact your installer or the WHES service team for confirmation if you're not sure whether your chosen battery is an approved battery.
2. This section mainly describes cable connections on the inverter side. Refer to the instructions supplied by the battery manufacturer for battery side connections and configurations.

### 2.3.7 Communication Connections

#### 2.3.7.1 BMS Connections

The BMS is used to communicate with connected compatible lithium batteries.

##### Connection Steps

1. Confirm that the battery and inverter power cables are connected.
2. Connect the inverter BMS communication cable to the lithium battery communication port.

The BMS cable uses 568B standard crimping.

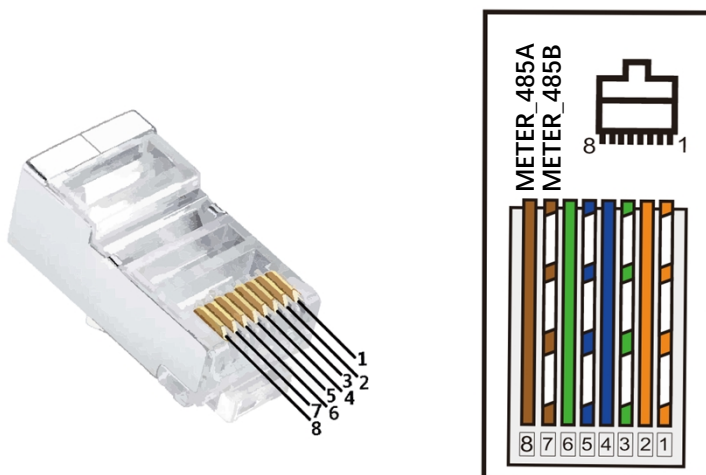

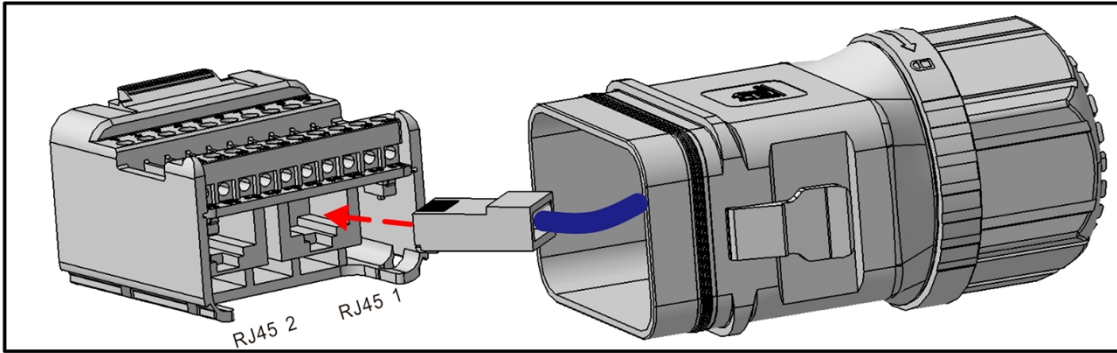

### 2.3.7.2 Meter Connections



Make sure the AC cable is completely isolated from AC power before connecting the Meter and CT.

- **Three Phase Meter** cable requirements as below.

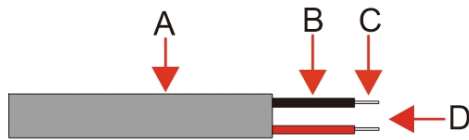

Legend	Description	Value
A	Outer Diameter	5-6mm
B	Individual Cable Length	22-32mm
C	Insulated Cable Length	7-8mm
D	Conductor Core	20AWG

• **Three Phase Meter** connection process is as below:

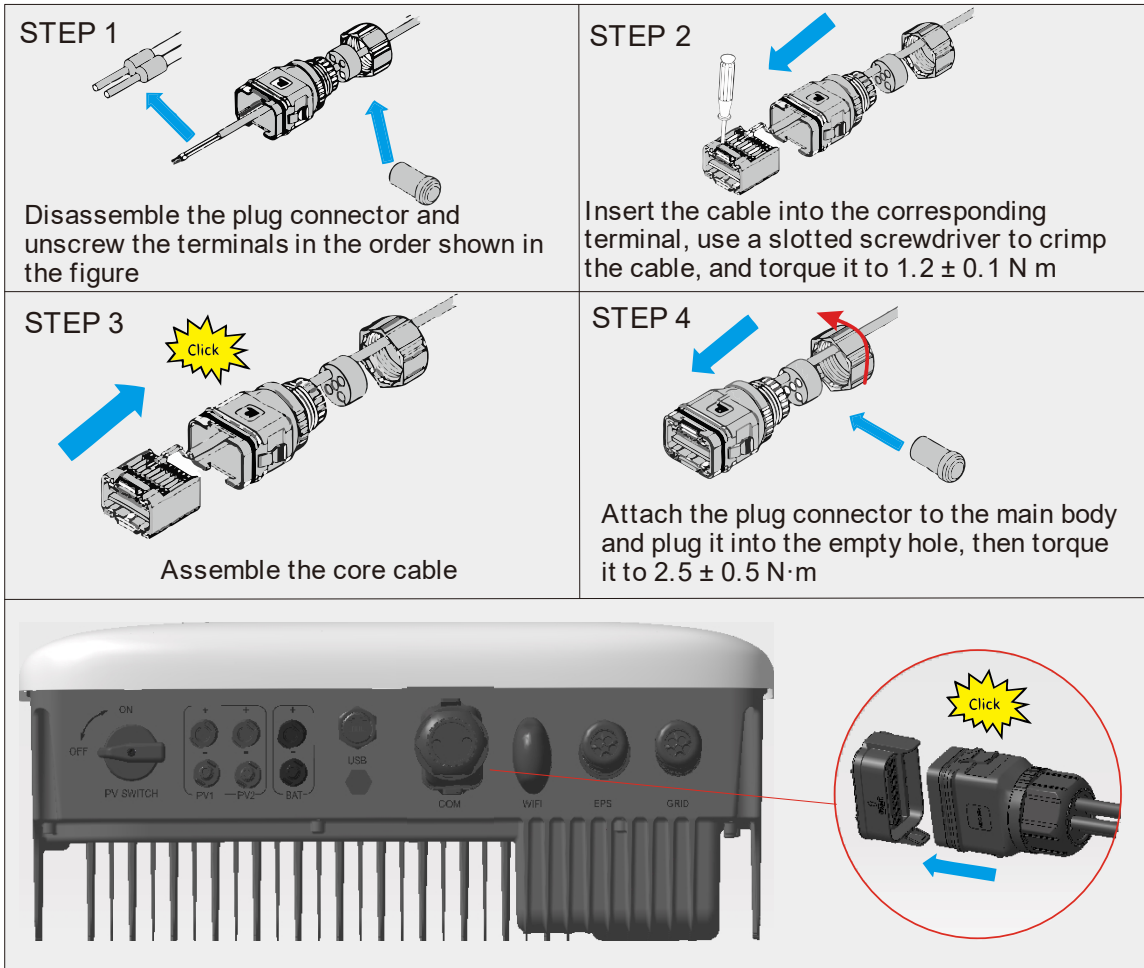

**Three Phase Meter** Wiring Diagram

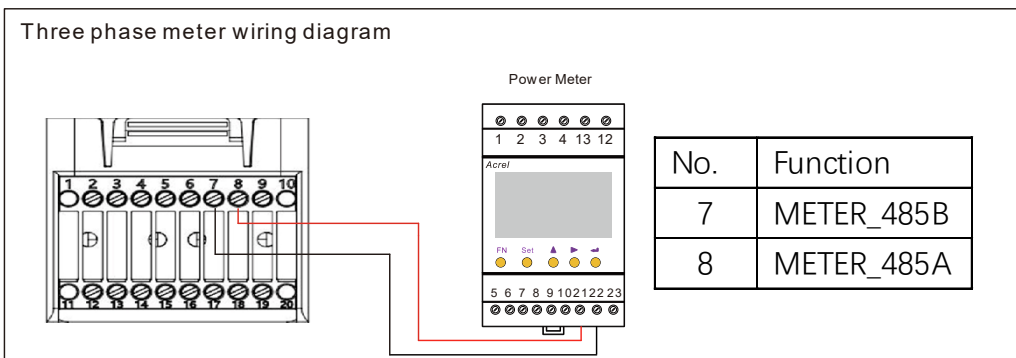

COM definitions below

No.	Function	No.	Function
1	COM/DRM0	11	CANL_OUT
2	REFGEN	12	CANH_OUT
3	DRM1/5	13	IN+
4	DRM2/6	14	IN-
5	DRM3/7	15	RLY1_IN
6	DRM4/8	16	OUT_12V
7	METER_485B	17	RLY2_IN
8	METER_485A	18	RLY2_OUT
9	VPP_485A	19	GND_COM
10	VPP_485B	20	VCC_COM

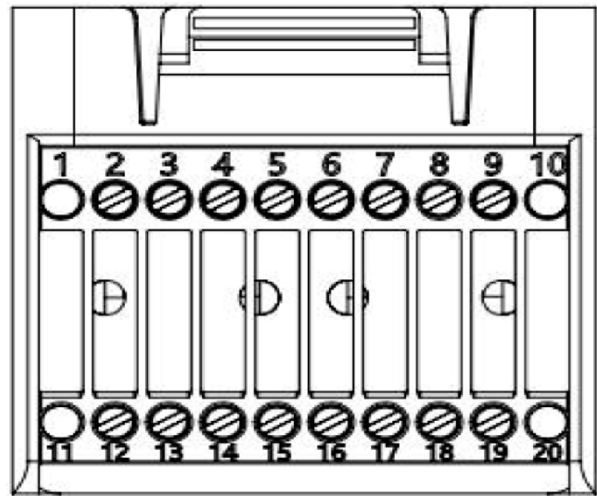

BMS		METER	
1	BMS_485A	1	NC
2	BMS_485B	2	NC
3	BMS_CANL	3	NC
4	BMS_CANH	4	NC
5	NC	5	NC
6	NC	6	NC
7	NC	7	METER_485B
8	NC	8	METER_485A

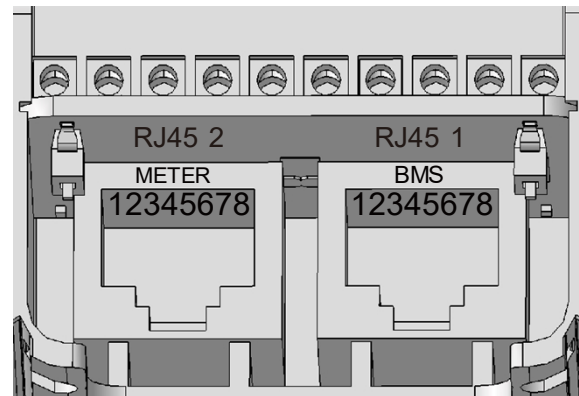

### 2.3.8 Wi-Fi Dongle Connection

Insert the Wi-Fi dongle included in the accessory package into the base and

tighten the plastic nut.

Torque 2.5 N·m

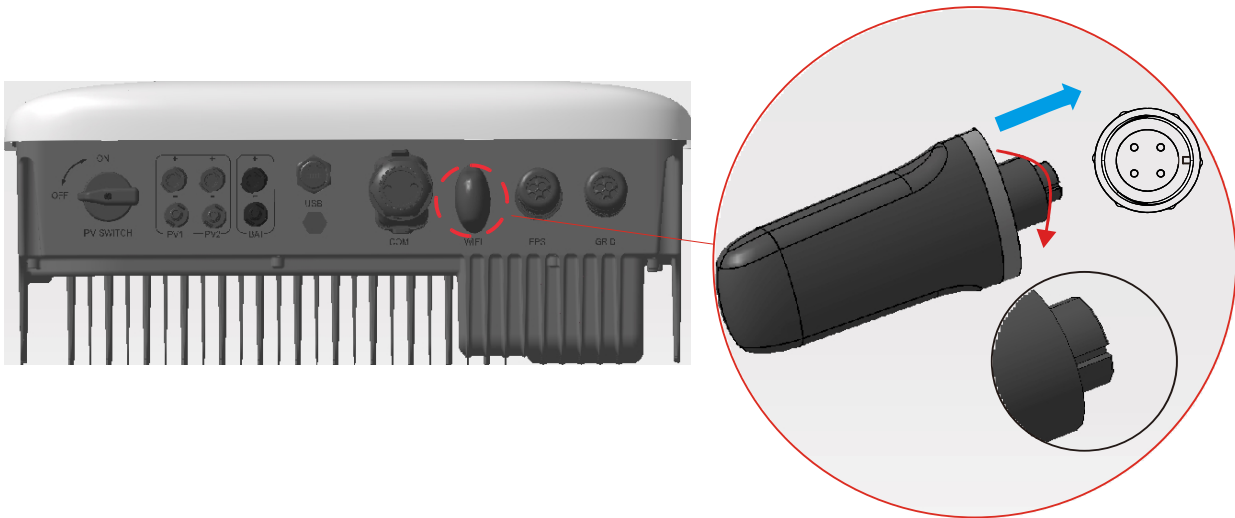

### 2.3.9 System Wiring Diagram

Please use an appropriate breaker based on the following specifications:

#### NOTE

1. Electrical short circuits on the grid side will damage the inverter if an AC breaker is not installed.
2. This diagram illustrates the wiring diagram for Copia series hybrid inverters, not the electrical wiring standards.
3. Please make sure that the AC line matches the "L1", "L2", "L3", "N", and the grounding port of the AC terminal completely when wiring. If the cable is connected incorrectly, the device may be damaged.

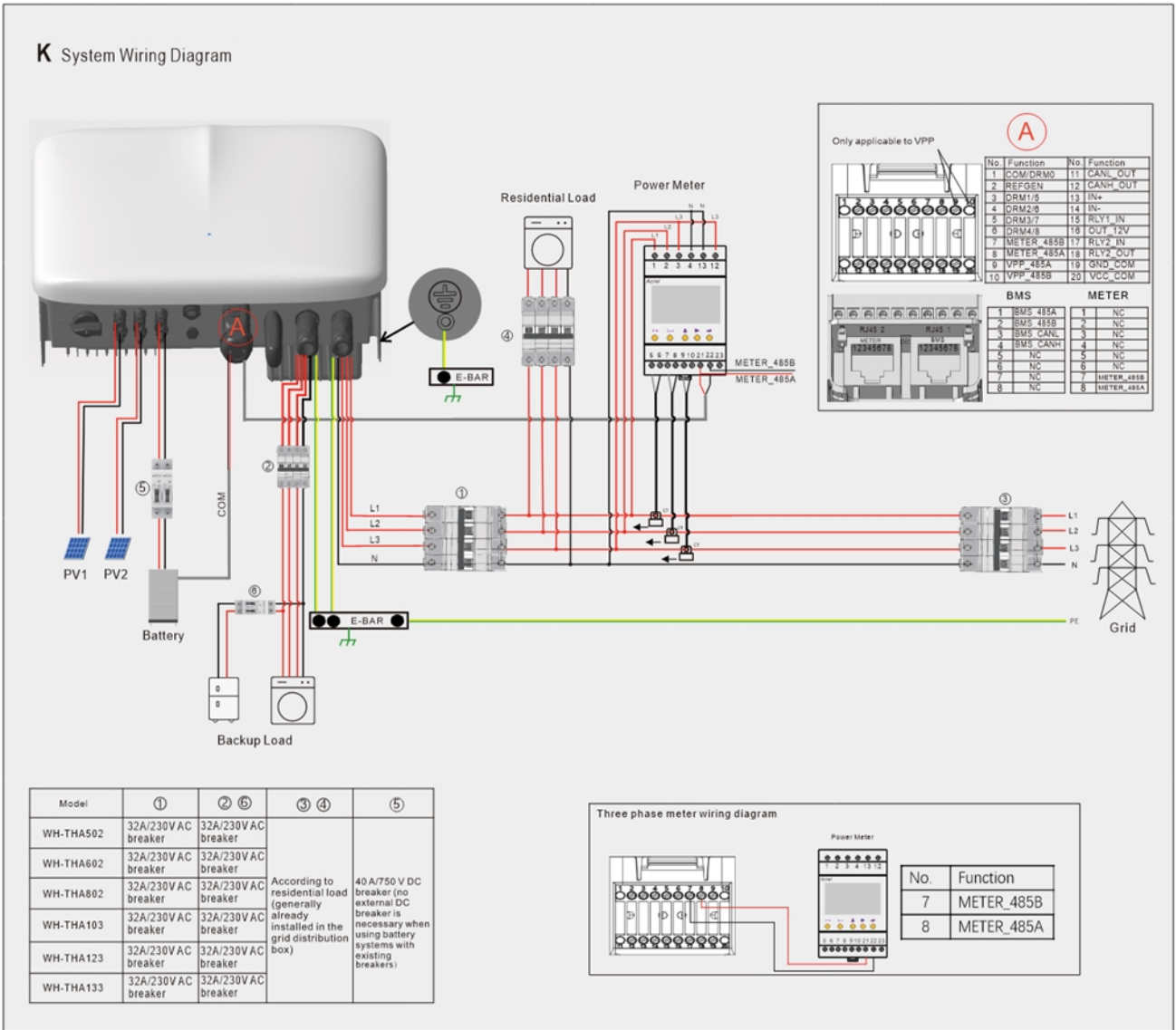

**Choose the correct breaker:**

Model	①	② ⑥	③ ④	⑤
WH-THA502	32A/230V AC breaker	32A/230V AC breaker		
WH-THA602	32A/230V AC breaker	32A/230V AC breaker		
WH-THA802	32A/230V AC breaker	32A/230V AC breaker	According to residential load (generally already installed in the grid distribution box)	40 A/750 V DC breaker (no external DC breaker is necessary when using battery systems with existing breakers)
WH-THA103	32A/230V AC breaker	32A/230V AC breaker		
WH-THA123	32A/230V AC breaker	32A/230V AC breaker		
WH-THA133	32A/230V AC breaker	32A/230V AC breaker		

● System Connection Diagrams

The following diagram illustrates an example use case where the neutral wire is separate from the PE in the distribution box. Please follow local wiring regulations.

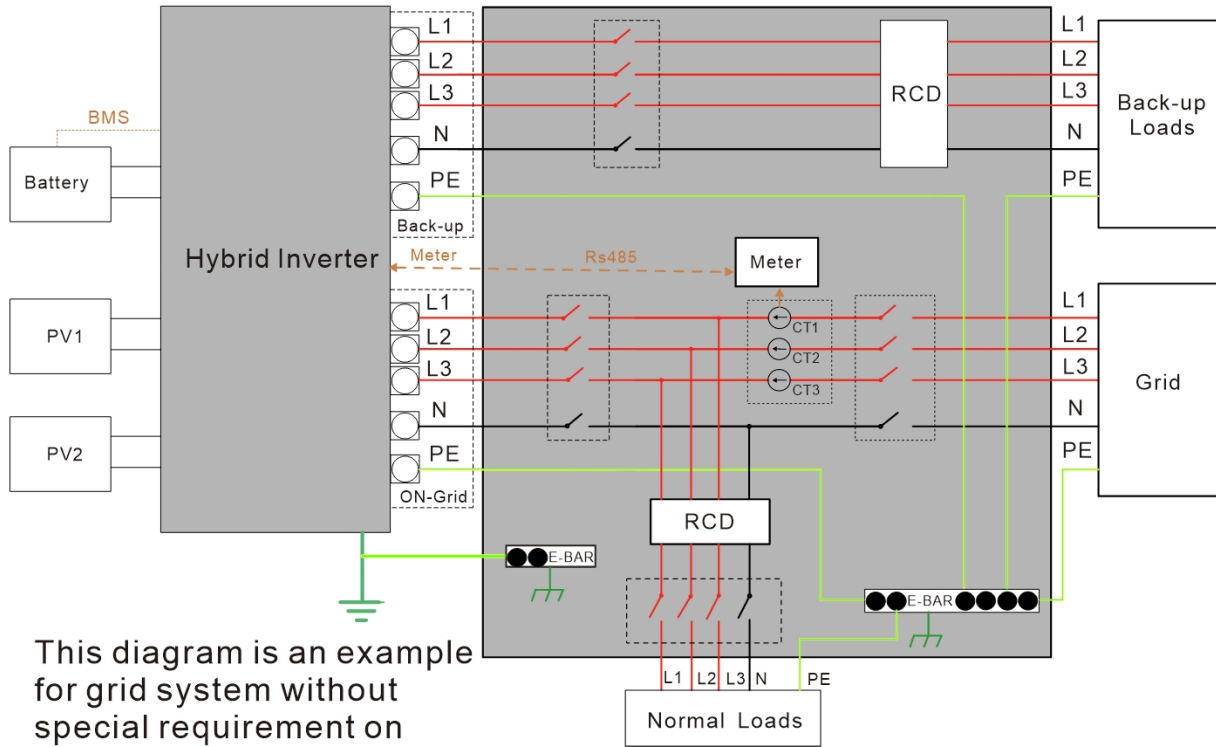

**Note:** Under Australian safety standards, the On-Grid and Back-Up neutral wires must be connected together, or the Back-Up function will not work.

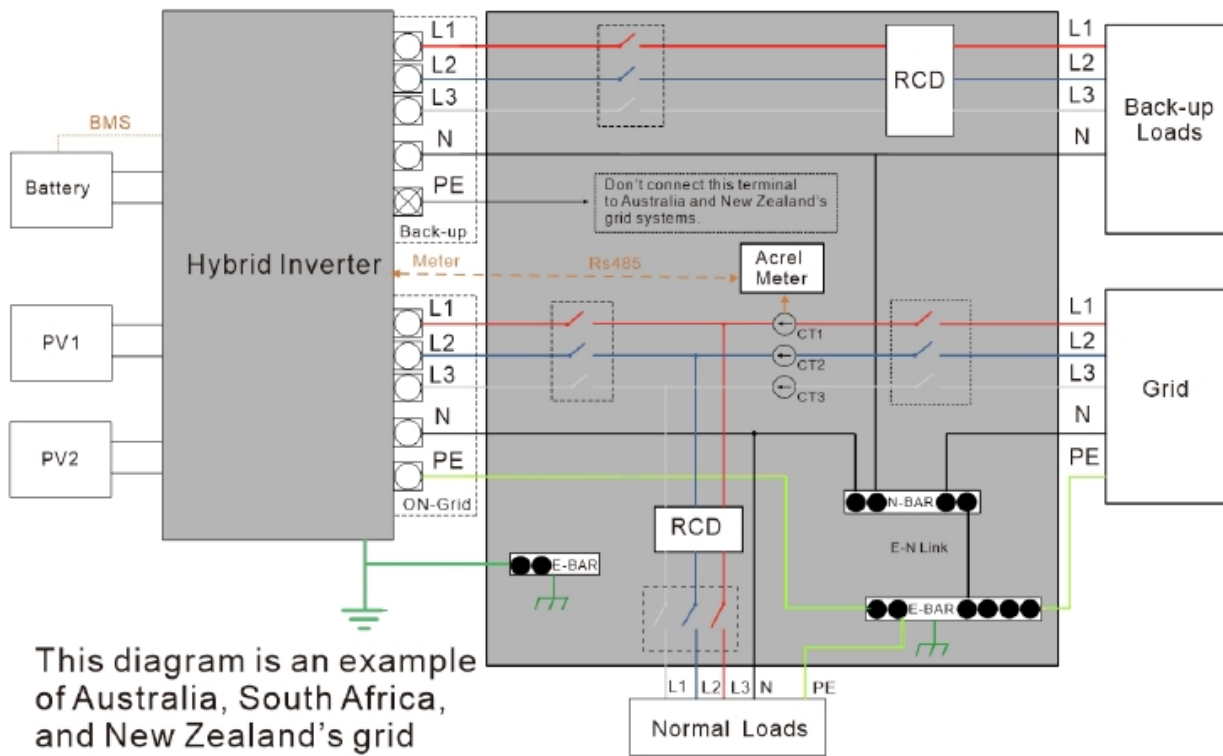

## 3 EMERGENCIES

### 3.1 Emergency Procedures

Turn off the main grid breaker directly feeding the inverter and turn off all inverter switches if the WH-THA inverter appears to be malfunctioning. Please immediately contact WHES for detailed instructions.

**WARNING: Do not open the inverter upper cover plate by yourself.**

### 3.2 First Aid Procedures

Avoid touching any liquid or gas leaking out of battery modules. Immediately do the following upon exposure to leaked battery liquids or gases:

**Skin contact:** Remove any contaminated clothes and rinse the affected area with plenty of water or run it under a shower for at least 15 minutes. Seek medical attention immediately.

**Eye contact:** Immediately flush the eyes with plenty of water for at least 15 minutes, occasionally lifting the upper and lower eyelids. Seek medical attention immediately.

**Inhalation:** Cover the victim in a blanket, move them into the fresh air, and keep them calm. Seek medical attention immediately. Begin artificial respiration immediately in the event of shortness of breath or difficulty breathing, or asphyxia (choking).

**Ingestion:** Give the patient at least 2 glasses of milk or water to drink. Induce vomiting unless the patient is unconscious. Seek medical attention immediately.

### 3.3 Firefighting Measures

**Extinguishing media:** Dry powder, sand, carbon dioxide (CO<sub>2</sub>), or water. Fire precautions and protective measures:

**Flammable properties:** Lithium-ion batteries contain a flammable liquid electrolyte that may vent, ignite, or produce sparks when subjected to high temperatures (> 150°C) or when damaged or improperly used (e.g., mechanical damage or overcharging). Burning cells can ignite other batteries close by.

**Explosion data:** Severe mechanical abuse may rupture batteries. Batteries may explode when exposed to fire.

**Special protective equipment for firefighters:** Wear full protective gear and self-contained breathing apparatus with a full face mask in a pressure-demand or other positive pressure mode in case of fire.

## 4 CONFIGURATION & WI-FI RELOAD

This part demonstrates the configuration step by step.

### 4.1 Preparations

1. A router connected to the Internet is required to connect to the ECOS application center.
2. Android or iOS smartphone.

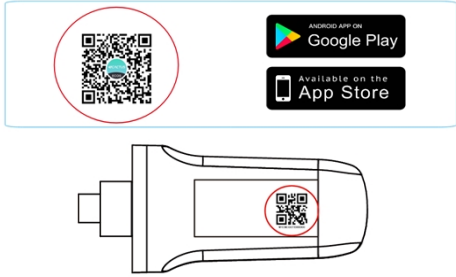
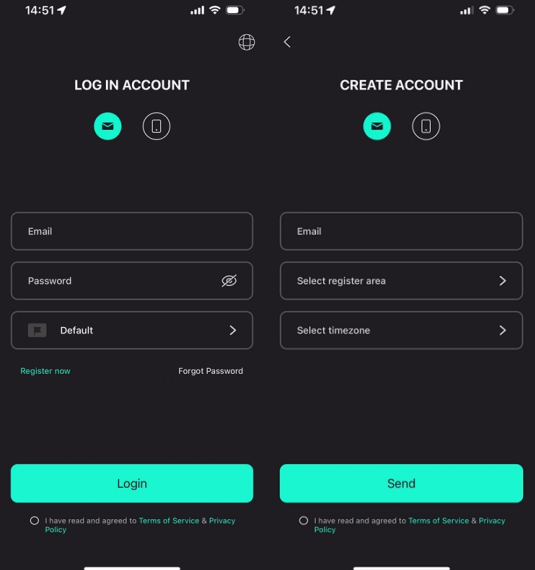
<p><b>STEP 1</b></p> <ol style="list-style-type: none"> <li>1. Scan the QR code on the front of the device to install the Android or iOS version of the ECOS app, depending on your operating system.</li> </ol>	
<p><b>STEP 2</b></p> <ol style="list-style-type: none"> <li>1. Open the ECOS app and tap the sign-up button to register a new user account.</li> <li>2. Follow all the instructions given during the sign-up process to successfully connect the device to ECOS.</li> <li>3. The product ID QR code required for connection can be found on the included Wi-Fi dongle installed on the right side of the device.</li> </ol>	

## NOTE

1. Please ensure the correct router password is entered.
2. Make sure that the Wi-Fi dongle's wireless network connection is strong.
3. If everything is set up properly, the Wi-Fi LED on the inverter will change from slowly flashing to quick flashing and then become solid, indicating that the device has successfully connected to the Wi-Fi network.

## 4.2 Wi-Fi Reset & Restore

Wi-Fi Reset: Reconfigure the Wi-Fi dongle, and Wi-Fi settings will be reprocessed and saved.

Wi-Fi Restore: Restore the Wi-Fi dongle settings back to the default factory settings.

**Wi-Fi Reset:**

Please use your ECOS app to reset the Wi-Fi configuration.

Navigate to Settings and My Devices, access the Wi-Fi Configuration page, and follow the instructions to complete the Wi-Fi process.

**Wi-Fi Restore:**

You also need to configure Wi-Fi network after set Wi-Fi dongle back to factory setting.

**Wi-Fi Reset:**

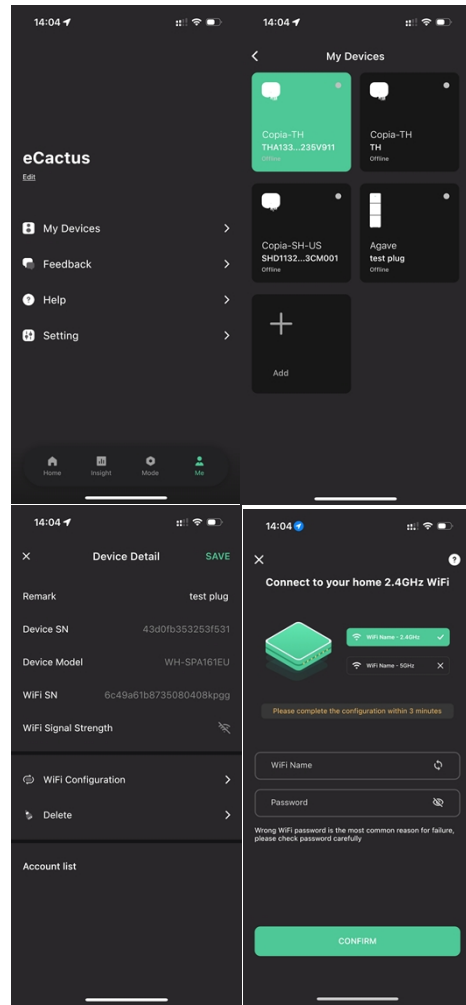

**Wi-Fi Restore:**

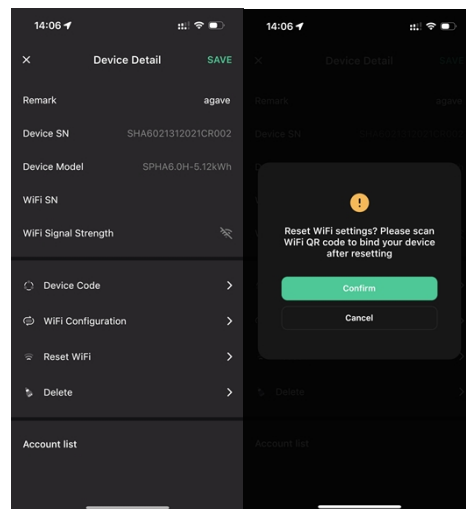

**4.3 Change Password & Delete Account**

## Change Password

You can change your password by navigating to “**Settings**” >> “**Security**” >> “**Change Password**” and entering your Original Password to set a new password.

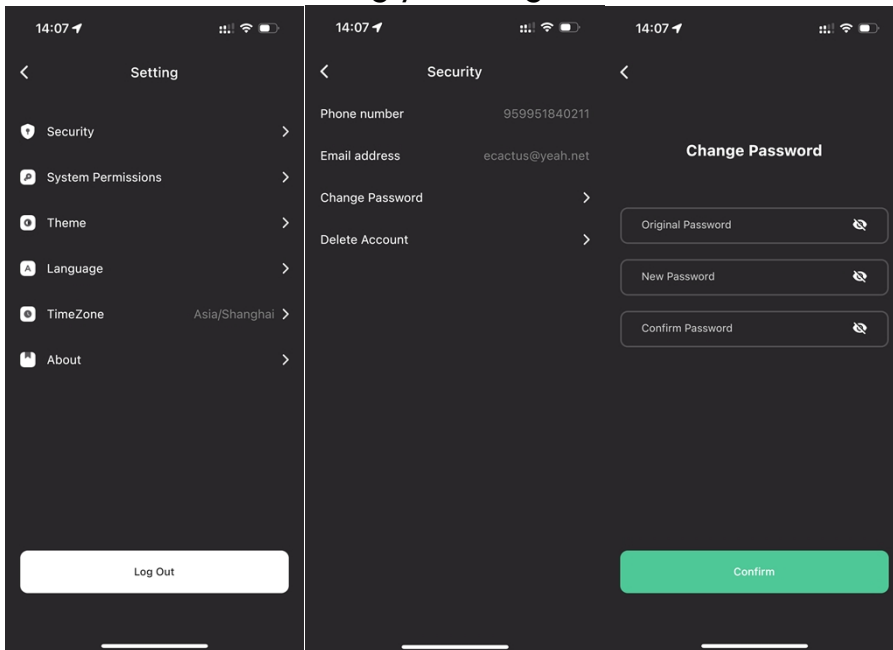

If you forget your password, you can reset your password by tapping “**Forgot Password**” on the login page and entering the verification code sent to your email address.

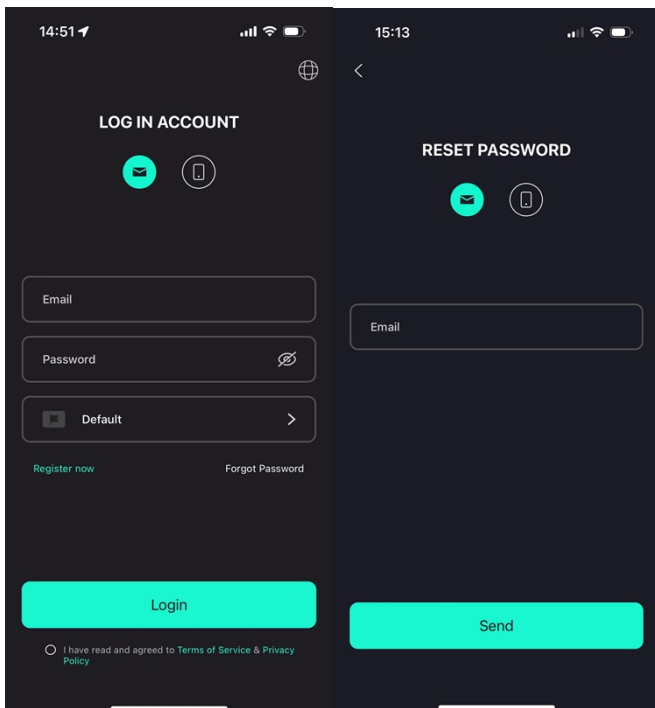

## Delete Account

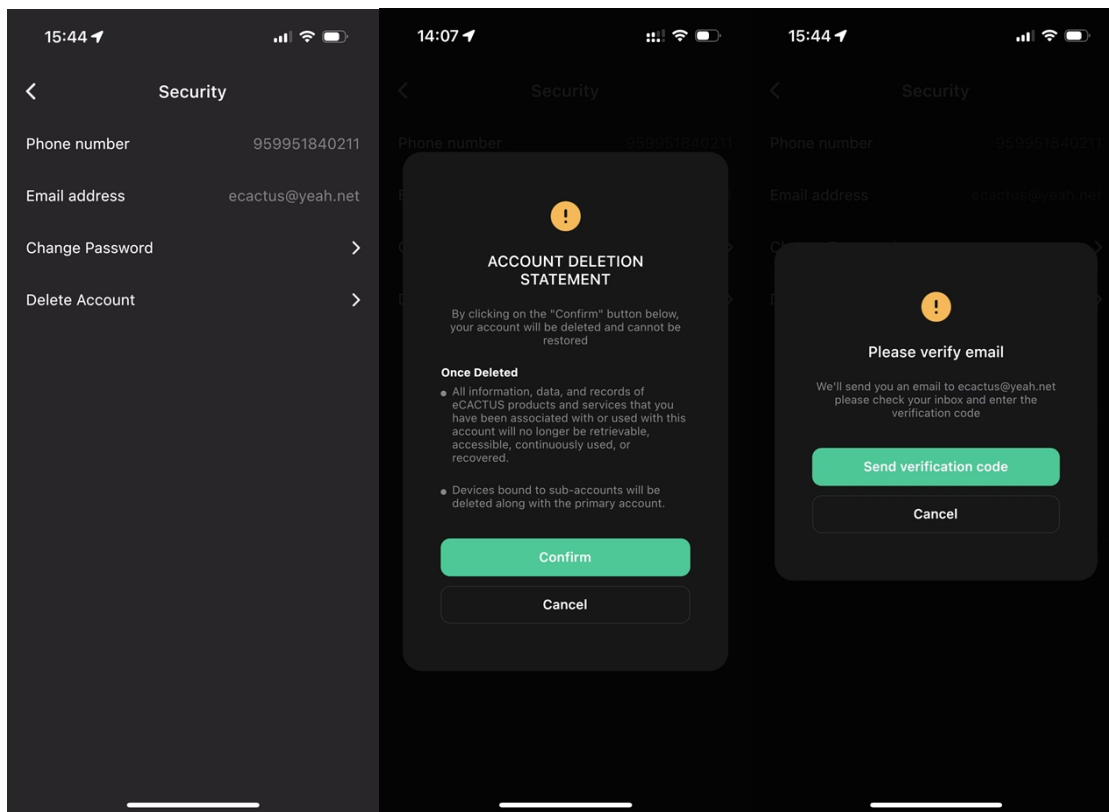

You can delete your account and data by navigating to “**Settings**” >> “**Security**”>> “**Delete Account.**” Please read the statement carefully before deleting your account.

**Notice:** You have 7 days to log back in and cancel your deletion request. Once deleted, your account and all associated data will be erased and cannot be recovered. When complete, we will send an email to your ECOS account to inform you that your account has been successfully deleted.

## 5 EMS CONFIGURATIONS

Energy management system (EMS) configurations can be set via the ECOS app or online website.

**Three working modes can be configured:**

### 1. Self-Powered:

EMS will manage residential power to minimize power grid reliance.

### 2. Load Shifting:

Batteries will be charged and discharged as configured.

### 3. Backup:

EMS will not discharge the battery unless the power grid is off. When this happens, EMS will provide residential power through the batteries.

#### Working Modes:

Navigate to the Customize tab and select one of the three operation modes via the ECOS app.

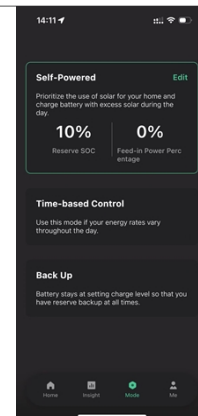

## 6 TROUBLESHOOTING

	Issue	Solution
1	Red LED flashing every 0.5 seconds	Meter Communication Fault. Please check whether the power supply & communication cables are properly connected in accordance with local standards.
2	Red LED flashing every 2 second	Battery Communication Fault. Please check whether the PCS is properly connected to the battery box, and make sure that the battery switch and breaker are both in the ON position.
3	Abnormal ECOS Energy Flow Monitoring	Please check whether the power supply and CT have been properly installed according to the installation manual.
4	All the LEDs are off	Please check whether the voltage at each port is within the normal range.
5	SOC mis-indicates and fluctuates after initial installation	Do nothing, and the device will self-correct itself as soon as the battery is fully charged or discharged.
6	Battery completely depleted	We highly recommend disconnecting the battery ASAP during installation or when the device is on standby to avoid serious depletion and damage caused by extreme power consumption over a long period of time. Please contact after-sale services for technical support in the event of serious battery depletion.
7	Code DSP_1	PV1 overvoltage. Please check whether the open circuit voltage is within the normal voltage range.
8	Code DSP_2	PV1 overcurrent. Please check whether PV1 is correctly connected.
9	Code DSP_3	PV2 overvoltage. Please check whether PV2 is within the rated voltage range.
10	Code DSP_4	PV2 overcurrent. Please check whether PV1 is correctly connected.
11	Code DSP_9	Please check whether PV is within the normal voltage range.
12	Code DSP_10	No grid power. Please check whether the grid voltage is normal.

	<b>Issue</b>	<b>Solution</b>
13	Code DSP_11	Grid voltage fault. Please check whether the grid voltage is within the normal range.
14	Code DSP_12	Grid current fault. Please check whether the EPS load power is within the normal range.
15	Code DSP_13	Grid frequency fault. Please check whether the grid frequency is within the normal range.
16	Code DSP_14	Overheat fault. Please check whether the cooling system is working properly.
17	Code DSP_16	Current over-leak fault. Please check the solar panel and device wiring.
18	Code DSP_17	Isolation resistance fault. Please check the solar panels and wiring system.
19	Code DSP_26	Battery voltage fault. Please check whether the battery voltage is within the normal range.
20	Code DSP_37	EPS voltage fault. Please check whether the EPS load power is within the normal range.
21	Code DSP_38	EPS current fault. Please check whether the EPS load power is within the normal range.
22	Code DSP_39	EPS overload fault. Please check whether the EPS load power is within the normal range.
23	Code DSP_40	EPS short circuit fault. Please check whether the EPS load power is within the normal range.
24	Code DSP_41	Earth & Neutral wire fault. Please check whether the earth and neutral wires are properly wired in line with standard requirements.
25	What should I do if I forget my ECOS password?	Please visit the ECOS website or use the app, tap "Forgot Password," enter your email address for verification, and follow the instructions to reset your password.
26	How can I change my ECOS password?	Log into ECOS and navigate to "Settings" >> "Security" >> "Change Password" to enter your new password.
27	How can I delete my device account?	Log into ECOS, then navigate to "Security" >> "Delete Account." Complete email verification to request Account Deletion. Deletion requests can be canceled by logging in within 7 days after requesting account deletion. All account data will

	Issue	Solution
		be deleted and will not be recoverable. Please think twice before deleting your account.
28	How can I share my ECOS account with my family members?	The first ECOS registered will be recognized as the master account, and others can scan the device code shared by the master account. Please navigate to "Settings" >> "My Device" >> "Device code" to share the code.
29	Why is there no data on the home page?	The device may be offline. 1- Check whether your Wi-Fi is working; 2- Check whether the LED is on; 3- Check whether the Wi-Fi dongle is properly connected; Data may take a while to upload, after which ECOS will be bound to the device. Poor mobile phone reception. Check whether the internet is working properly and try to restart ECOS.
30	Adding multiple devices to ECOS	Log in to the ECOS app and tap the "+" on the top left of the home page. Scan the QR code on the Wi-Fi dongle to add new devices. Or navigate to "Setting" >> "Devices" and tap the "+" to add more devices.
31	How can I delete my device account?	Log in to ECOS and navigate to "Setting" >> "My Devices," select the device account, and tap the top right of the screen to delete the device.
32	Why is the device offline	There are many possible reasons for the device to be offline. 1. Check whether the Wi-Fi network is working properly 2. Check whether the LED is on 3. Check whether the LED on the Wi-Fi dongle is on
33	Why can't I search for and find the Wi-Fi dongle hotspot?	1. Check whether the LED is on 2. Check whether the LED on the Wi-Fi dongle is on 3. Restart or reconnect the Wi-Fi dongle
34	Why is no internet connection found when	Disconnect your mobile phone from the WLAN, and reconnect it to your home Wi-Fi or your

	<b>Issue</b>	<b>Solution</b>
	returning to other interfaces after configuring ECOS via WLAN?	mobile network after successfully configuring WLAN.

## 7 CLEANING AND MAINTENANCE

**Power off the system before cleaning or performing any maintenance.**

● **Shut down procedures:**

Step 1: Disconnect the backup load where applicable, and then turn off the backup breaker.

Step 2: Turn off the grid breaker.

Step 3: Turn off the PV switch.

### 7.1 Cleaning

Power off the system before cleaning the inverter. Only clean the battery case with a soft, dry brush or vacuum cleaner to remove dirt. Do not use any solvents, abrasives, or corrosive liquids to clean the case.

### 7.2 Maintenance

The inverter requires periodically maintenance, details as below:

NOTE: Make sure inverter is totally isolated from all DC and AC power for at least 5 mins before maintenance.

Heat sink: please use clean towel to clean up heat sink once a year.

Torque: please use torque wrench to tighten AC and battery wiring connection once a Year.

## 8 ANNEX

### 8.1 Datasheet

Hybrid Spec.						
Series name:CopiaTH						
Model	WH- THA502	WH- THA602	WH- THA802	WH- THA103	WH- THA123	WH- THA133
<b>PV Input</b>						
Absolute max Voltage [d.c.V]	1000					
MPPT Voltage Range [d.c.V]	180...980					
Max. DC Input Power [W]	7500	9000	12000	15000	20000	20000
Start-up Voltage [d.c.V]	145					
Rated Operating Voltage [d.c.V]	620					
Max. Input Current [d.c.A]	18/18					
Max. inverter backfeed current to array[d.c.A]	0					
Isc PV[d.c.A]	22/22					
NO. of MPP Trackers	2					
NO. of Strings per MPP Tracker	1					
<b>Battery</b>						
<b>Li-ion</b>						
Battery Voltage Range [d.c.V]	160...700					
Max. Charge/Discharge Current [d.c.A]	25/25					
<b>AC Input/Output</b>						
Rated output Power [W]	5000	6000	8000	10000	12000	13000
Rated Apparent Power to Grid [VA]	5000	6000	8000	10000	12000	13000
Max. Apparent Power to Grid [VA]	5000	6000	8000	10000	12000	13000
Rated Apparent Power from Grid [VA]	10000	12000	16000	17900	17900	17900
Max. Apparent Power from Grid [VA]	10000	12000	16000	17900	17900	17900
Rated Voltage [a.c.V]	3/N/PE;220/380 3/N/PE;230/400 3/N/PE;240/415					
Rated Frequency [Hz]	50/60					
Rated AC Current to Grid[a.c.A]	7.3	8.7	11.6	14.5	17.4	18.9
Max. AC Current to Grid[a.c.A]	8.1	9.6	12.8	16.0	19.2	20.8

Rated AC Current from Grid[a.c.A]	14.6	17.4	23.2	26.0	26.0	26.0
Max. AC Current from Grid[a.c.A]	16.2	19.2	25.6	26.0	26.0	26.0
Inrush current[a.c.A]	16 a.c.A (peak), 11.3 us (duration)					
Max. output fault current[a.c.A]	52 (peak), 37 (rms)					
AC output Maximum output overcurrent protection[a.c.A]	37					
AC input power factor	-0.8...+0.8					
AC output power factor	1(-0.8...+0.8 adjustable)					
THDi	< 3%					
<b>EPS Output (With Battery)</b>						
Rated Output Power [W]	5000	6000	8000	10000	12000	13000
Peak Output Apparent Power [VA] @60 sec	10000	12000	16000	16000	16000	16000
Rated Voltage [a.c.V]	3/N/PE;220/380 3/N/PE;230/400 3/N/PE;240/415					
Nominal Frequency [Hz]	50/60 (±0.2%)					
Rated Output Current [a.c.A]	7.3	8.7	11.6	14.5	17.4	18.9
Inrush current[a.c.A]	16 a.c.A (peak), 11.3 us (duration)					
Max. output fault current[a.c.A]	52 (peak), 37 (rms)					
EPS output Maximum output overcurrent protection[a.c.A]	37					
Switch time [ms]	< 10					
THDv @ Linear Load [%]	< 2					
Power Factor	-0.8...+0.8					
<b>Efficiency</b>						
PV Max. Efficiency[%]	98					
PV Europe Efficiency[%]	97					
PV Max. MPPT Efficiency[%]	99.9					
Battery Charge by PV Max. Efficiency[%]	98.5					
Battery Discharge Efficiency[%]	97.7					
<b>Protection</b>						
Over/Under voltage protection	Yes					
DC isolation protection	Yes					
DC injection monitoring	Yes					
Residual current detection	Yes					
Anti-islanding protection	Yes					
Over load protection	Yes					

Battery Input reverse polarity protection	Yes
PV reverse polarity protection	Yes
Surge protection	Yes
Over heat protection	Yes
<b>General Data</b>	
Dimension (W/D/H)[mm]	510*205*480
Dimension of Packing (W/D/H)[mm]	700*360*605
Net weight [kg]	30.8
Gross weight [kg]	35
Operation Temp [°C]	-25...+60
Relative Humidity[%]	0...95
Altitude [m]	<= 3000
Ingress Protection	IP65
Cooling	Natural
Inverter Topology	Non-isolated
Over voltage category	III(AC), II(DC)
Protective class	Class I
Active anti-islanding method	frequency shift
Human Interface	LED/APP
BMS Communication Interface	RS485/CAN
Meter Communication Interface	RS485
Noise Emission [dB]	< 25
Standby Power Consumption [W]	< 10

## 9 LABELS

**EC**ACTUS

Hybrid Inverter:

<b>Type</b>	WH-THA502	
<b>PV INPUT</b>	Max.DC input power	7500W
	Absolute max. voltage	DC 1000V
	MPPT voltage range	DC 180...980V
	Rated operating voltage	DC 620V
	Max. input current	DC 18/18A
	Isc PV	DC 22/22A
<b>AC INPUT</b>	Rated voltage	3/N/PE AC 380/400/415V
	Rated current	AC 14.6A
	Max.input current	AC 16.2A
	Rated frequency	50/60Hz
	Max.apparent power	10000VA
	Power factor	-0.8...+0.8
<b>AC OUTPUT</b>	Rated power	5000W
	Rated apparent power	5000VA
	Max. apparent power	5000VA
	Rated frequency	50/60Hz
	Rated voltage	3/N/PE AC 380/400/415V
	Rated output current	AC 7.3A
	Max.output current	AC 8.1A
Power factor	1(-0.8...+0.8 adjustable)	
<b>EPS OUTPUT</b>	Rated voltage	3/N/PE AC 380/400/415V
	Max.output current	AC 8.1A
	Rated frequency	50/60Hz
	Rated apparent power	5000VA
	Max. apparent power	5000VA
Power factor	-0.8...+0.8	
<b>Battery</b>	Battery type	Li-ion
	Battery Voltage Range	DC 160...700V
	Max.Charge/Discharge Current	DC 25A
Ingress protection	IP65	
Operation temperature range	-25°C...+60°C	
Inverter topology	Non-isolated	
Over voltage category	III (AC) ,II (DC)	
Protective class	Class I	



Jiangsu Weiheng Intelligent Technology Co.,Ltd.  
 Address : Sheng Xiang, Yaxi Community, Luoshe Town, Huishan District, 214000 , Wuxi City, Jiangsu Province  
 www.weiheng-tech.com Made in China

**EC**ACTUS

Hybrid Inverter:

<b>Type</b>	WH-THA602	
<b>PV INPUT</b>	Max.DC input power	9000W
	Absolute max. voltage	DC 1000V
	MPPT voltage range	DC 180...980V
	Rated operating voltage	DC 620V
	Max. input current	DC 18/18A
	Isc PV	DC 22/22A
<b>AC INPUT</b>	Rated voltage	3/N/PE AC 380/400/415V
	Rated current	AC 17.4A
	Max.input current	AC 19.2A
	Rated frequency	50/60Hz
	Max.apparent power	12000VA
	Power factor	-0.8...+0.8
<b>AC OUTPUT</b>	Rated power	6000W
	Rated apparent power	6000VA
	Max. apparent power	6000VA
	Rated frequency	50/60Hz
	Rated voltage	3/N/PE AC 380/400/415V
	Rated output current	AC 8.7A
	Max.output current	AC 9.6A
Power factor	1(-0.8...+0.8 adjustable)	
<b>EPS OUTPUT</b>	Rated voltage	3/N/PE AC 380/400/415V
	Max.output current	AC 9.6A
	Rated frequency	50/60Hz
	Rated apparent power	6000VA
	Max. apparent power	6000VA
Power factor	-0.8...+0.8	
<b>Battery</b>	Battery type	Li-ion
	Battery Voltage Range	DC 160...700V
	Max.Charge/Discharge Current	DC 25A
Ingress protection	IP65	
Operation temperature range	-25°C...+60°C	
Inverter topology	Non-isolated	
Over voltage category	III (AC) ,II (DC)	
Protective class	Class I	



Jiangsu Weiheng Intelligent Technology Co.,Ltd.  
 Address : Sheng Xiang, Yaxi Community, Luoshe Town, Huishan District, 214000 , Wuxi City, Jiangsu Province  
 www.weiheng-tech.com Made in China



Hybrid Inverter:

Type	WH-THA802	
PV INPUT	Max.DC input power	12000W
	Absolute max. voltage	DC 1000V
	MPPT voltage range	DC 180...980V
	Rated operating voltage	DC 620V
	Max. input current	DC 18/18A
	Isc PV	DC 22/22A
AC INPUT	Rated voltage	3/N/PE AC 380/400/415V
	Rated current	AC 23.2A
	Max.input current	AC 25.6A
	Rated frequency	50/60Hz
	Max.apparent power	16000VA
	Power factor	-0.8...+0.8
AC OUTPUT	Rated power	8000W
	Rated apparent power	8000VA
	Max. apparent power	8000VA
	Rated frequency	50/60Hz
	Rated voltage	3/N/PE AC 380/400/415V
	Rated output current	AC 11.6A
EPS OUTPUT	Rated output current	AC 12.8A
	Rated voltage	3/N/PE AC 380/400/415V
	Max.output current	AC 12.8A
	Rated frequency	50/60Hz
	Rated apparent power	8000VA
	Max. apparent power	8000VA
Battery	Power factor	-0.8...+0.8
	Battery type	Li-ion
	Battery Voltage Range	DC 160...700V
	Max.Charge/Discharge Current	DC 25A
	Ingress protection	IP65
	Operation temperature range	-25°C...+60°C
Inverter topology	Non-isolated	
Over voltage category	III (AC) ,II (DC)	
Protective class	Class I	



Jiangsu Weiheng Intelligent Technology Co.,Ltd.

Address : Sheng Xiang, Yaxi Community, Luoshe Town, Huishan District, 214000 , Wuxi City, Jiangsu Province  
www.weiheng-tech.com Made in China



Hybrid Inverter:

Type	WH-THA103	
PV INPUT	Max.DC input power	15000W
	Absolute max. voltage	DC 1000V
	MPPT voltage range	DC 180...980V
	Rated operating voltage	DC 620V
	Max. input current	DC 18/18A
	Isc PV	DC 22/22A
AC INPUT	Rated voltage	3/N/PE AC 380/400/415V
	Rated current	AC 26A
	Max.input current	AC 26A
	Rated frequency	50/60Hz
	Max.apparent power	17900VA
	Power factor	-0.8...+0.8
AC OUTPUT	Rated power	10000W
	Rated apparent power	10000VA
	Max. apparent power	10000VA
	Rated frequency	50/60Hz
	Rated voltage	3/N/PE AC 380/400/415V
	Rated output current	AC 14.5A
EPS OUTPUT	Max.output current	AC 16.0A
	Rated voltage	3/N/PE AC 380/400/415V
	Max.output current	AC 16.0A
	Rated frequency	50/60Hz
	Rated apparent power	10000VA
	Max. apparent power	10000VA
Battery	Power factor	-0.8...+0.8
	Battery type	Li-ion
	Battery Voltage Range	DC 160...700V
	Max.Charge/Discharge Current	DC 25A
	Ingress protection	IP65
	Operation temperature range	-25°C...+60°C
Inverter topology	Non-isolated	
Over voltage category	III (AC) ,II (DC)	
Protective class	Class I	



Jiangsu Weiheng Intelligent Technology Co.,Ltd.

Address : Sheng Xiang, Yaxi Community, Luoshe Town, Huishan District, 214000 , Wuxi City, Jiangsu Province  
www.weiheng-tech.com Made in China



Hybrid Inverter:

<b>Type</b>	WH-THA123	
<b>PV INPUT</b>	Max.DC input power	20000W
	Absolute max. voltage	DC 1000V
	MPPT voltage range	DC 180...980V
	Rated operating voltage	DC 620V
	Max. input current	DC 18/18A
	Isc PV	DC 22/22A
<b>AC INPUT</b>	Rated voltage	3/N/PE AC 380/400/415V
	Rated current	AC 26A
	Max.input current	AC 26A
	Rated frequency	50/60Hz
	Max.apparent power	17900VA
	Power factor	-0.8...+0.8
<b>AC OUTPUT</b>	Rated power	12000W
	Rated apparent power	12000VA
	Max. apparent power	12000VA
	Rated frequency	50/60Hz
	Rated voltage	3/N/PE AC 380/400/415V
	Rated output current	AC 17.4A
<b>EPS OUTPUT</b>	Max.output current	AC 19.2A
	Rated frequency	50/60Hz
	Rated apparent power	12000VA
	Max. apparent power	12000VA
	Power factor	-0.8...+0.8
	<b>Battery</b>	Battery type
Battery Voltage Range		DC 160...700V
Max.Charge/Discharge Current		DC 25A
Ingress protection		IP65
Operation temperature range		-25°C...+60°C
Inverter topology		Non-isolated
Over voltage category	III (AC) ,II (DC)	
Protective class	Class I	



Jiangsu Weiheng Intelligent Technology Co.,Ltd.  
 Address : Sheng Xiang, Yaxi Community, Luoshe Town, Huishan District, 214000 , Wuxi City, Jiangsu Province  
 www.weiheng-tech.com Made in China



Hybrid Inverter:

<b>Type</b>	WH-THA133	
<b>PV INPUT</b>	Max.DC input power	20000W
	Absolute max. voltage	DC 1000V
	MPPT voltage range	DC 180...980V
	Rated operating voltage	DC 620V
	Max. input current	DC 18/18A
	Isc PV	DC 22/22A
<b>AC INPUT</b>	Rated voltage	3/N/PE AC 380/400/415V
	Rated current	AC 26A
	Max.input current	AC 26A
	Rated frequency	50/60Hz
	Max.apparent power	17900VA
	Power factor	-0.8...+0.8
<b>AC OUTPUT</b>	Rated power	13000W
	Rated apparent power	13000VA
	Max. apparent power	13000VA
	Rated frequency	50/60Hz
	Rated voltage	3/N/PE AC 380/400/415V
	Rated output current	AC 18.9A
<b>EPS OUTPUT</b>	Max.output current	AC 20.8A
	Rated frequency	50/60Hz
	Rated apparent power	13000VA
	Max. apparent power	13000VA
	Power factor	-0.8...+0.8
	<b>Battery</b>	Battery type
Battery Voltage Range		DC 160...700V
Max.Charge/Discharge Current		DC 25A
Ingress protection		IP65
Operation temperature range		-25°C...+60°C
Inverter topology		Non-isolated
Over voltage category	III (AC) ,II (DC)	
Protective class	Class I	



Jiangsu Weiheng Intelligent Technology Co.,Ltd.  
 Address : Sheng Xiang, Yaxi Community, Luoshe Town, Huishan District, 214000 , Wuxi City, Jiangsu Province  
 www.weiheng-tech.com Made in China